

The 1572 series represents one of the most popular styles of wire bonding capillaries in the industry today. This series combines the popular 8° face angle with a 120° double inside chamfer. The 8° face angle provides excellent 2nd bond characteristics on a variety of surfaces. The 120° double inside chamfer exerts maximum downward force on the ball bond and provides good looping characteristics. Selected 1572 style tools are regular stock items based on demand.

The 1572N may be specified for a 90° inside chamfer for improved 2nd bond tailing and a more compact ball bond on materials with good bondability.

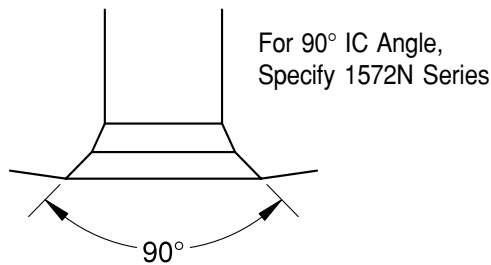
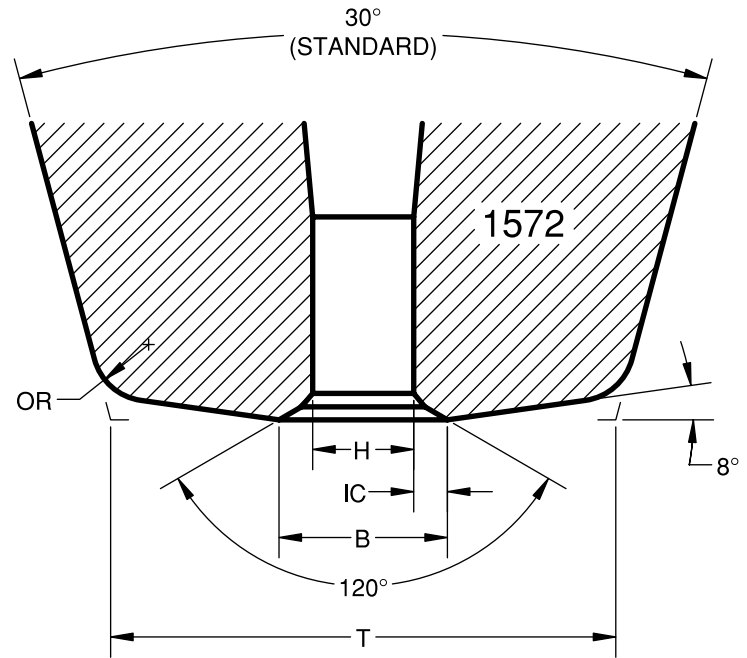

**Specify:** Series - Dash Number - Length+Finish - Options  
**Example:** 1572-18-437GM

Note: For Tungsten Carbide material, specify 1172 & 1172N series (1/16 in. diameter only).  
 For 1/8 in. diameter ceramic, specify 1272 & 1272N series.

SERIES & DASH NO.	H* in./μm ±.0001/2.5	IC in./μm (ref)	B** in./μm ±.0002/5	OR in./μm ±.0003/8	T (30° CONE) in./μm ±.0003/8	T (20° CONE) in./μm ±.0003/8	SUGGESTED WIRE DIAMETER in./μm
1572-10	.0010/25	.0007/18	.0024/61	.0008/20	.0055/140	.0056/142	.0005/13 to .0008/20
1572-10S	.0010/25	.0004/10	.0018/46	.0008/20	.0055/140	.0056/142	
1572-12	.0012/30	.0006/15	.0024/61	.0008/20	.0055/140	.0056/142	.0007/18 to .0009/23
1572-13	.0013/33	.0006/15	.0025/64	.0008/20	.0055/140	.0056/142	.0008/20 to .0010/25
1572-13S	.0013/33	.0004/10	.0021/53	.0008/20	.0055/140	.0056/142	
1572-15	.0015/38	.0007/18	.0029/74	.0010/25	.0065/165	.0067/170	.0009/23 to .0011/28
1572-15S	.0015/38	.0006/15	.0027/69	.0008/20	.0055/140	.0056/142	
1572-17	.0017/43	.0006/15	.0029/74	.0010/25	.0090/229	.0092/234	.0010/25 to .0013/33
1572-17S	.0017/43	.0006/15	.0029/74	.0010/25	.0065/165	.0067/170	
1572-18	.0018/46	.0006/15	.0030/76	.0010/25	.0090/229	.0092/234	.0013/33 to .0015/38
1572-20	.0020/51	.0010/25	.0040/102	.0015/38	.0090/229	.0093/236	
1572-22	.0022/56	.0009/23	.0040/102	.0015/38	.0090/229	.0093/236	.0015/38 to .0020/51
1572-25	.0025/64	.0013/33	.0051/130	.0020/51	.0115/292	.0118/300	
1572-30	.0030/76	.0013/33	.0056/142	.0025/64	.0130/330	.0134/340	.0020/51
1572-35	.0035/89	.0010/25	.0055/140	.0030/76	.0140/356	.0145/368	.0020/51 to .0025/64
1572-40	.0040/102	.0010/25	.0060/152	.0030/76	.0140/356	.0145/368	.0030/76
1572-50	.0050/127	.0013/33	.0076/193	.0030/76	.0160/406	.0165/419	.0040/102
1572-70	.0070/178	.0015/38	.0100/254	.0050/127	.0280/711	.0288/732	.0050/127
1572-100	.0100/254	.0020/51	.0140/356	.0070/178	.0380/965	.0391/993	.0060/152

\* For hole sizes less than 0.0011 and hole sizes 0.0025 through 0.0049, the tolerance is +.0002/-.0001. For hole sizes greater than 0.0049, the tolerance is +.0003/-.0002. Tighter tolerance available at additional charges.

\*\* For B dimensions greater than 0.0040, the tolerance is +.0003/-.0002. *Dimensions in inches unless otherwise specified*