

The flat face series vacuum pick-up tools hold the die against the face of the tool and are used for die attach. Generally, this process is used for epoxy die attach but can be used in some cases for eutectic bonding on smaller die sizes.

Tungsten carbide can be used for the tip material but may cause undesirable scratching on the die surface in some cases. When die scratching is a concern, Vespel or Delrin plastic-tipped tools are recommended.

Delrin is the softest of the materials but can be easily damaged if mishandled. Also, Delrin can pick up a static charge which may be detrimental to some types of devices such as CMOS.

Delrin's upper service temperature is 180°F (82°C).

Vespel is a more durable, rigid plastic that generally does not hold a static charge and is rated for continuous operation at 500°F (260°C).

If the die is rotating during pick-up with a larger die, then a rectangular face pick-up tool may be used to help reduce the problem.

All vacuum pick-up tools are available on shanks listed on the shank styles pages for die collets and vacuum pick-up tools. If a particular shank is not listed, Gaiser Tool Co. can manufacture it per customer specifications.

3900 Series Conical Tip

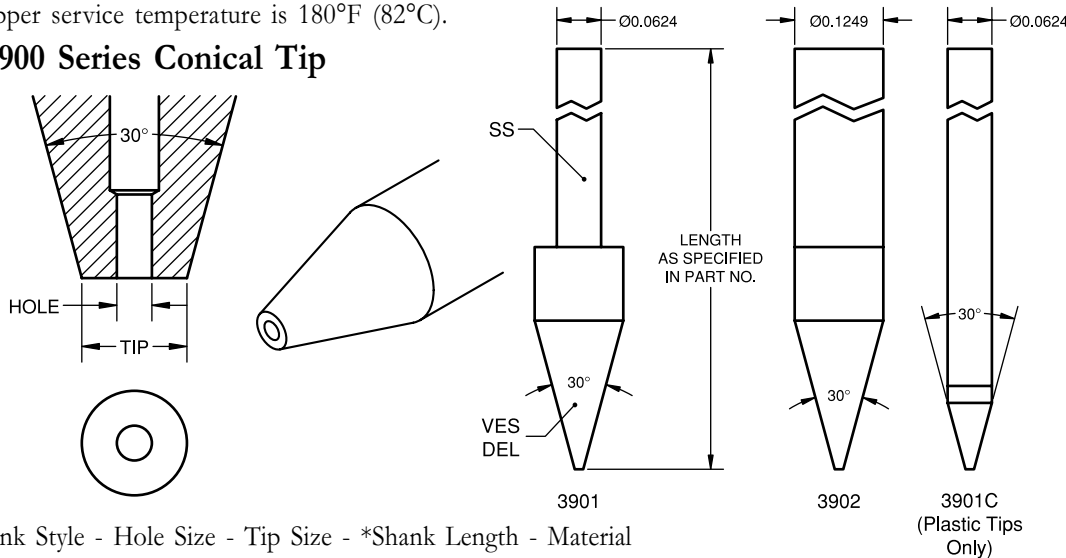

TYPICAL TIP CONFIGURATIONS	
HOLE DIAMETER in./μ	TIP DIAMETER in./μ
.005/127	.010/254
.006/152	.012/305
.008/203	.012/305
.008/203	.014/356
.010/254	.018/457
.010/254	.025/635
.015/381	.030/762
.020/308	.040/1016

Specify:

Series/Shank Style - Hole Size - Tip Size - *Shank Length - Material

Example:

3901-006-012-625-DEL

*Specify length for 01, 02, & 60 shanks only

VES, DEL, or WC material. Polish face standard for WC material

3800 Series Rectangular Tip

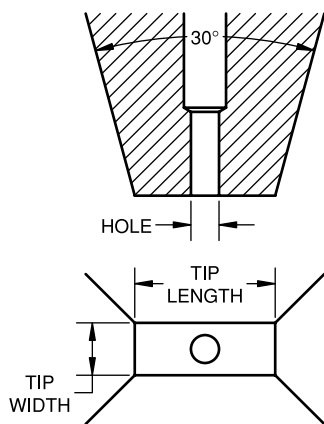

Specify:

Series/Shank Style - Hole - Tip Length - Tip Width - *Length - Matl

Example:

3802-010-025-035-750-VES

*Specify length for 01, 02, & 60 shanks only

VES or WC only. Polish face standard for WC material

3300 Series Perimeter Pick-Up

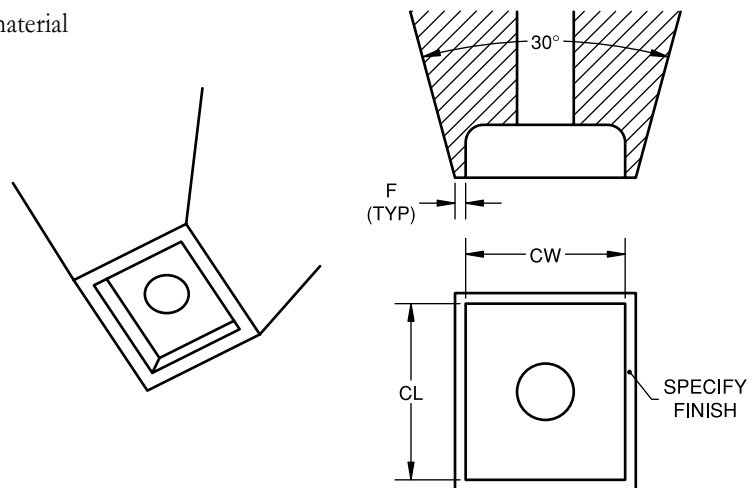

Specify:

Series/Shank Style - *Shank Length - CL - CW - F - Finish

Example:

3302-1.0-050-040-003-P

*Specify length for 01, 02, & 60 shanks only

**P=Polish GM=Gaiser Matte

WC only