

DASH NUMBER	W	T	G	C
-09101	.009	.010	.0010	.020
-10051	.010	.005	.0010	.015
-10052	.010	.005	.0020	.015
-10102	.010	.010	.0020	.020
-15152	.015	.015	.0020	.050
-18202	.018	.020	.0020	.050
-20204	.020	.020	.0040	.050
-20307	.020	.030	.0070	.050

Dimensions in inches unless otherwise specified

Material:
 Molybdenum

Specify: Parallel Gap Electrode - Dash Number - Style
 Example:
 PGE-09101-60D

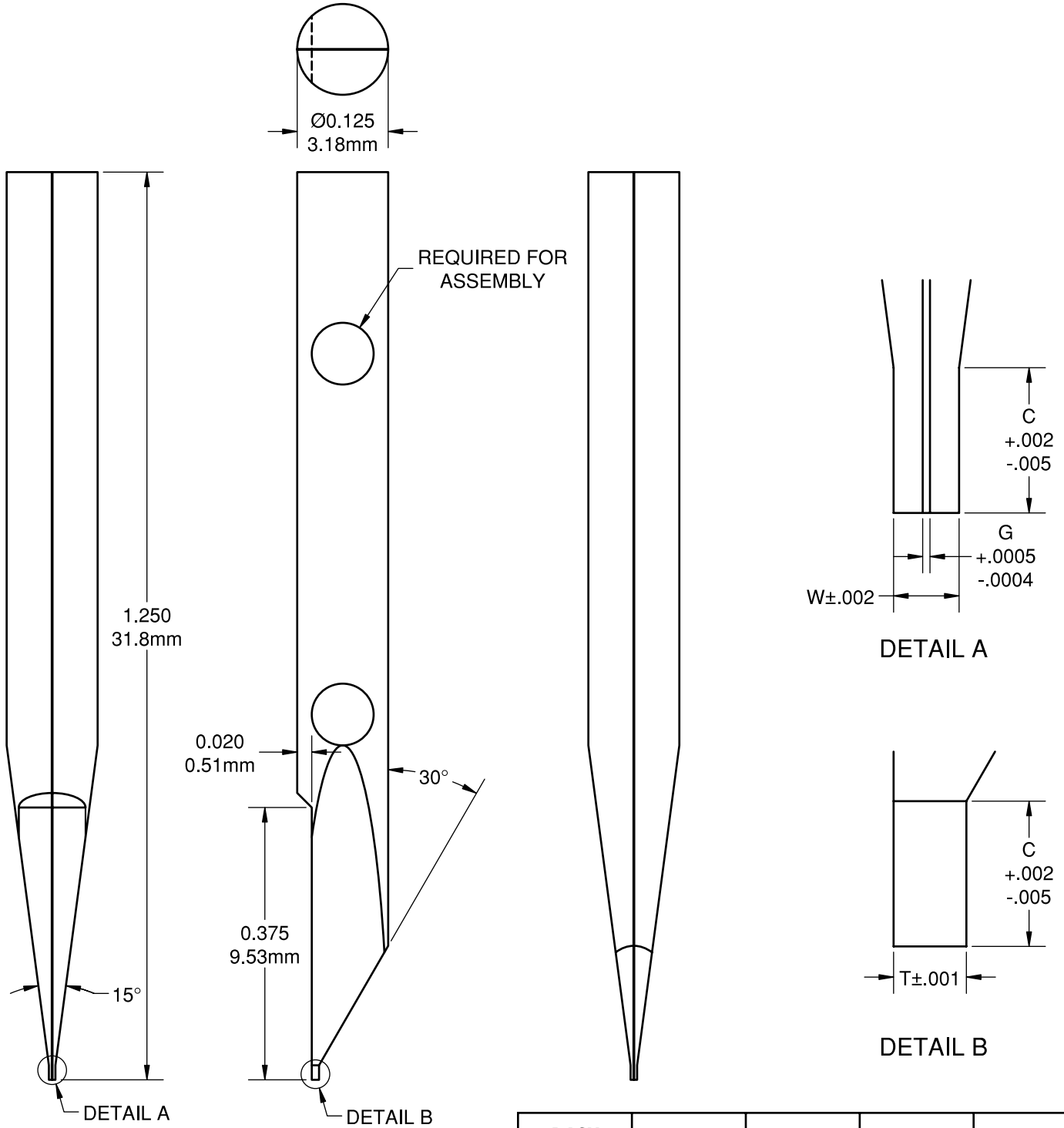

Material:
 Molybdenum

Specify: Parallel Gap Electrode - Dash Number - Style
 Example:
 PGE-09101-15D

DASH NUMBER	W	T	G	C
-09101	.009	.010	.0010	.020
-10051	.010	.005	.0010	.015
-10052	.010	.005	.0020	.015
-10102	.010	.010	.0020	.020
-15152	.015	.015	.0020	.050
-18202	.018	.020	.0020	.050
-20204	.020	.020	.0040	.050
-20307	.020	.030	.0070	.050

Dimensions in inches unless otherwise specified