

2100 Series

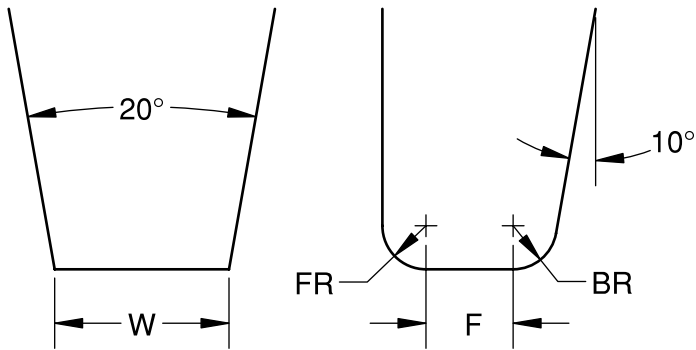

Specify: 2100(W-FR-F-BR)-Length-Shank Dia.

2100A Series

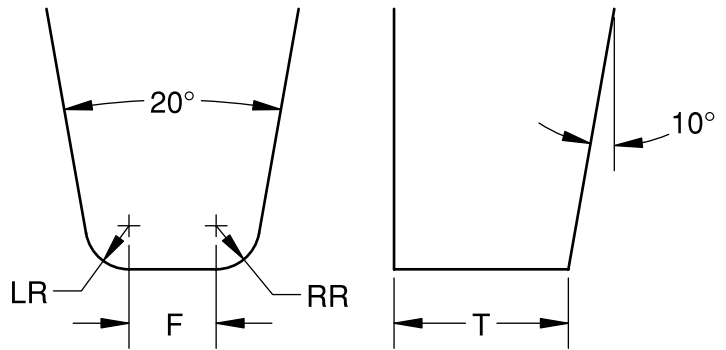

Specify: 2100A(T-LR-F-RR)-Length-Shank Dia.

Example:
 Series _____ 2100(40-10-20-5)-S-1/16
 W("40"=0.0040 inch) _____
 FR("10"=0.0010 inch) _____
 F("20"=0.0020 inch) _____
 BR("5"=0.0005 inch) _____
 Shank Length("S"=0.437 inch) _____
 Shank("1/16"=See Table) _____

2100B Series

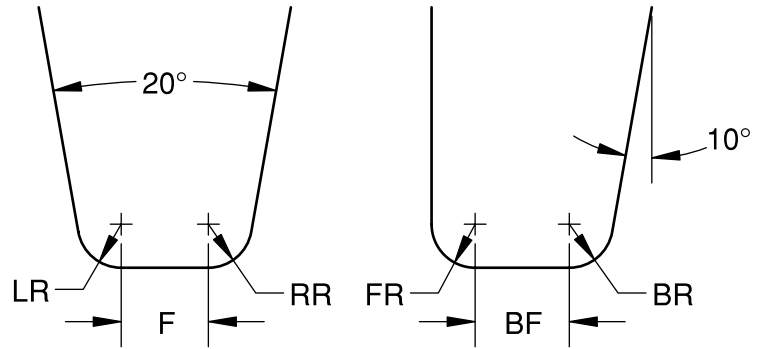

Specify: 2100B(F-BF-FR-BR-LR-RR)-Length-Shank Dia.

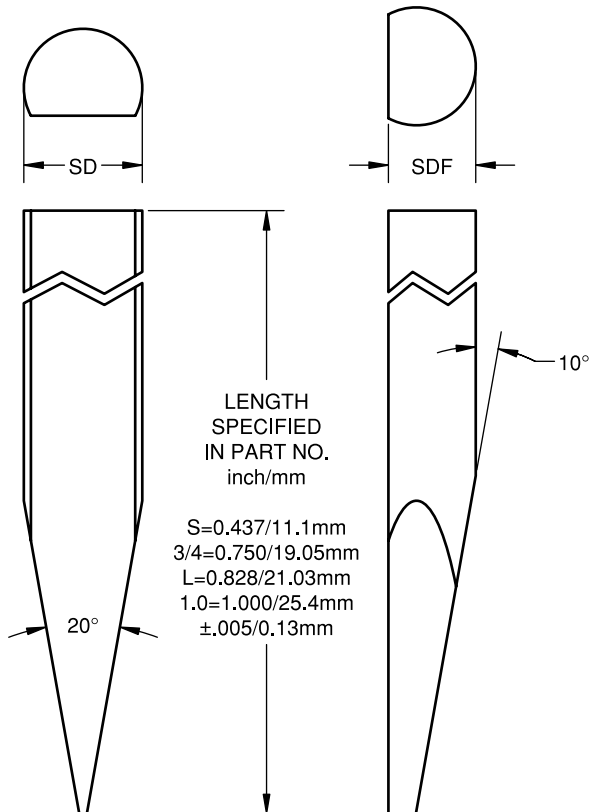

SHANK TABLE		
SHANK	SHANK DIAMETER (SD) in./mm +.0001/.003 -.0002/.005	SHANK DIAMETER FLAT (SDF) in./mm ±.0005/.013
1/16	0.0624/1.585	0.0460/1.168
1/16A	0.0624/1.585	0.0590/1.500
2mm	0.0786/2.000	0.0630/1.600
3/32	0.0936/2.377	0.0880/2.235
3mm	0.1179/2.995	0.0900/2.290
1/8	0.1249/3.172	0.1180/3.000