

The deep access wedge design was created in order to meet the challenge of bonding into deep cavity packages. The high walls of these packages make access with conventional 30°, 45°, and 60° wedge bonders very difficult. With a conventional bonder, the position of the wire clamps behind the bonding wedge limits access in the deep package. Also, the wire may be impeded between the wire clamps and the wedge by these walls.

Deep access wedge bonders feed the wire vertically down the center of the tool. The wire clamp is located above the wedge instead of behind the wedge. This clamp position allows the wedge to penetrate deep cavity packages.

The deep access bonding wedge is a combination of both a wedge and a capillary. The wire travels through the center of the wedge shank, exits down toward the bottom, out the back of the shank, and re-enters through the wire feed hole at either a 45° or 60° angle. This innovation in wedge bonding has provided the opportunity for small bond lengths into deep cavity packages.

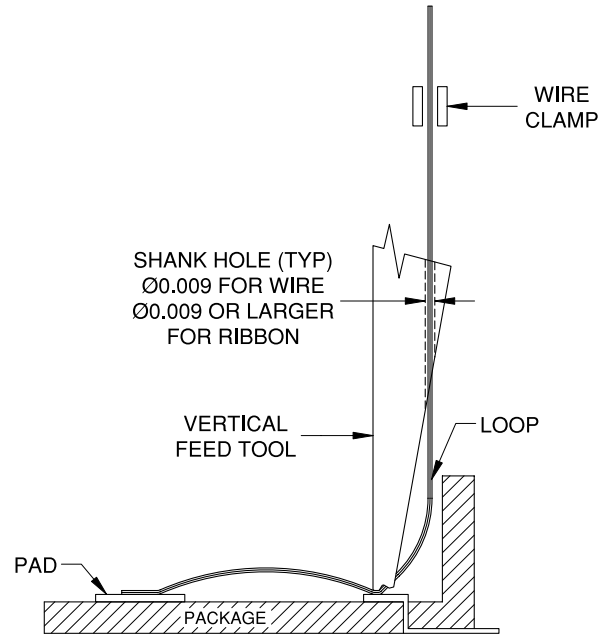

Standard Shank for
 4445, 4645, 4660, 4645R, & 4660R

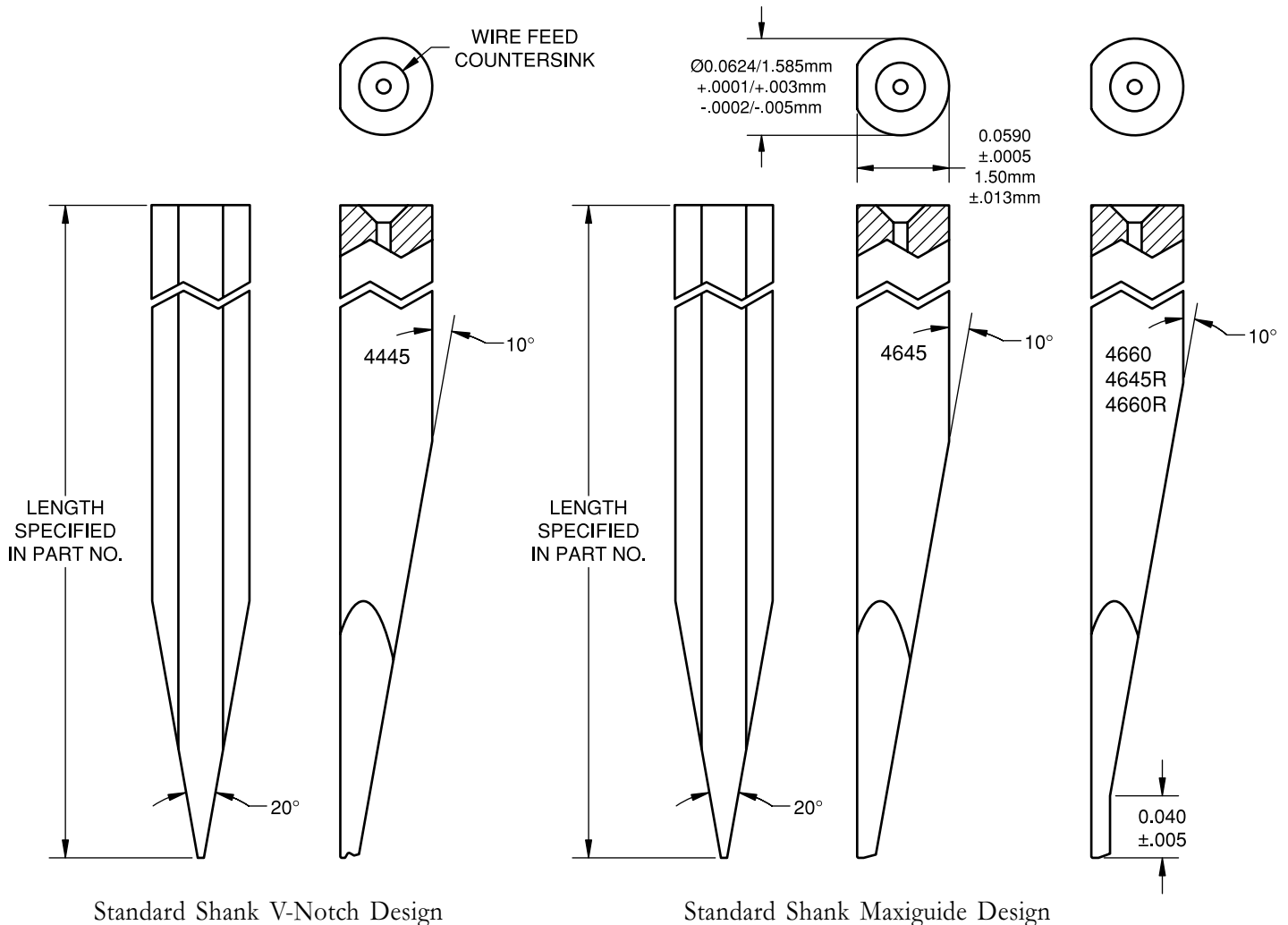

Standard Shank V-Notch Design

Standard Shank Maxiguide Design

The close guide shank design locates the shank hole close to the wedge hole for optimum tail length control.

The following bonding machines use the deep access tool:

- Hybond Model 572
- K&S Model 4129
- Mech El Model 990
- West Bond Model 4600 & 7400A-46

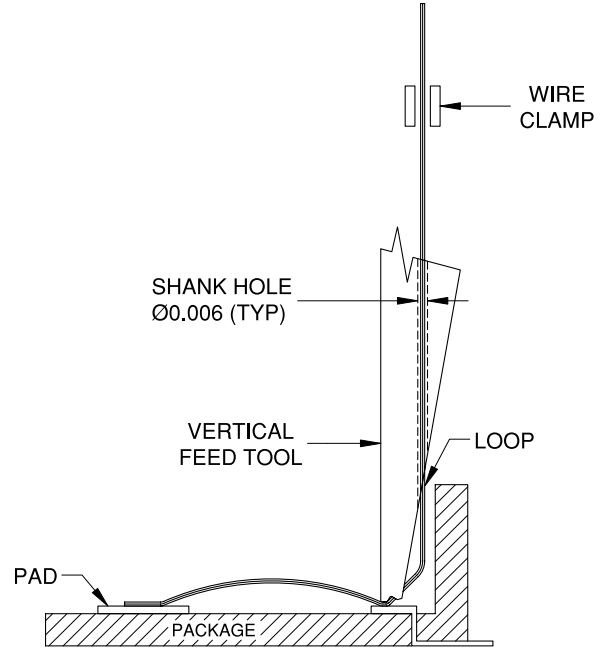

Close Guide Shank for 4345, 4545, 4560
 (Not Available for Ribbon)

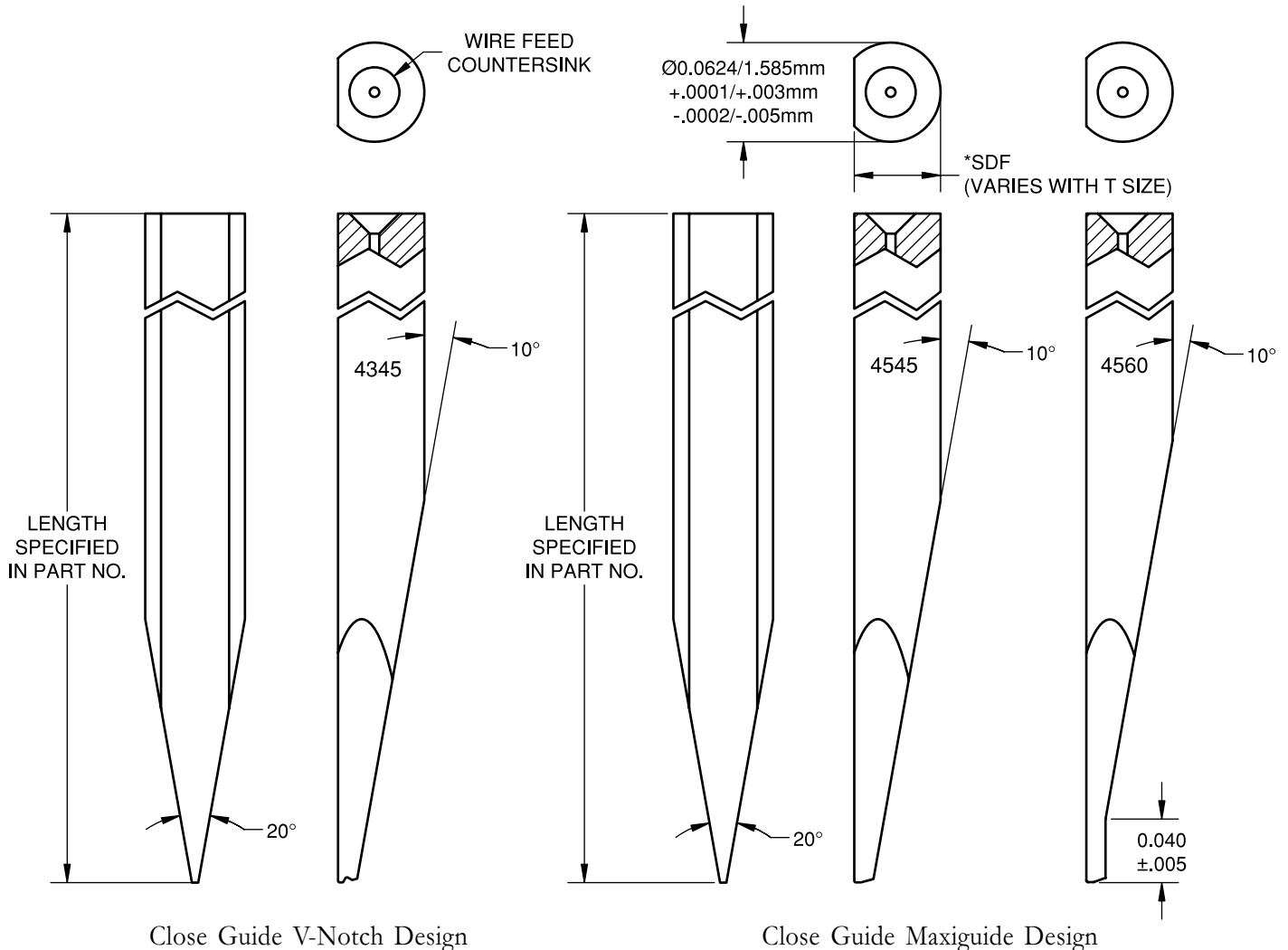

Close Guide V-Notch Design

Close Guide Maxiguide Design